

NOTES:

- All the soldering procedures upon microphones must be completed in a metallic device and the temperature of the soldering iron must be limited to $320\pm 20^{\circ}\text{C}$ and the soldering time should not exceed 3 seconds.
- Operators, the soldering fixture and the soldering iron must be statically grounded under each soldering process.

1. ELECTRICAL SPECIFICATIONS

Standard Conditions

Ordinary Temperature	15 to 35°C
Ordinary Humidity	45 to 75%
Ordinary air pressure	86 to 106kPa

Basic Test Conditions

Temperature	$20 \pm 2^{\circ}\text{C}$
Humidity	60 to 70%
Ordinary air pressure	86 to 106kPa

Parameter		SPEC.	Unit
Directional Characteristic		Omni-Directional	—
Sensitivity		-42±2	dB
Impedance		2.2(Max)	kΩ
S/N Ratio (A weighted network)		58(Min)	dB
Maximum Input Sound Pressure Level		110	dB
Standard Operating Voltage		2	Vdc
Operating Voltage Range		1.0~10	Vdc
Decrease Voltage Characteristics(Vs=2.0 to 1.5V dc)		-3(Max)	dB
Current Consumption		≦ 500	μA
Standard Test Circuit		See Fig. 1	—
Frequency Response Characteristic		See Fig. 2	—
Memo	Standard test condition	RL=2.2kΩ, Vs=2V dc (@f=1kHz, Pin=1Pa, 0dB=1V/pa)	

2. STANDARD TEST CIRCUIT

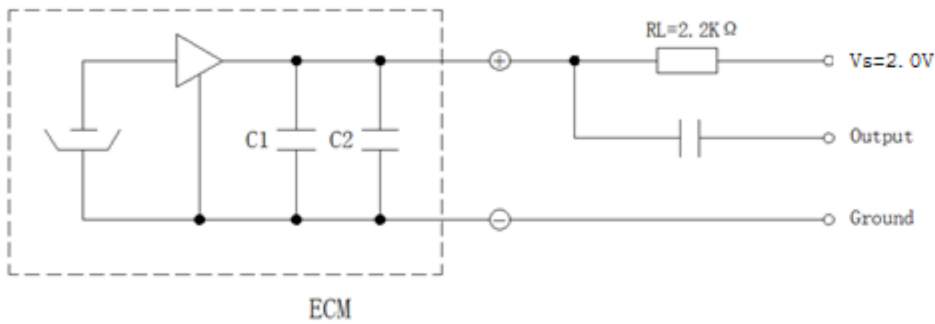

Fig.1

RL=2.2K Ω (External resisto

Vs=2.0V

C1=33pF

C2=10pF

3. TYPICAL FREQUENCY RESPONSE

Fig.2

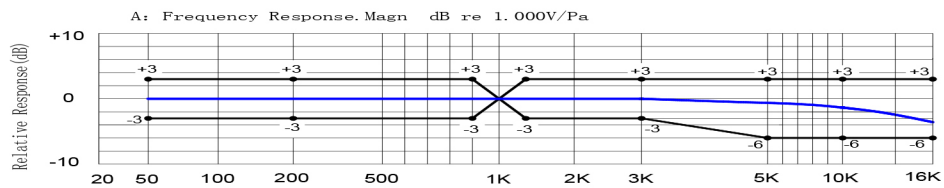

4. MEASUREMENT SYSTEM:

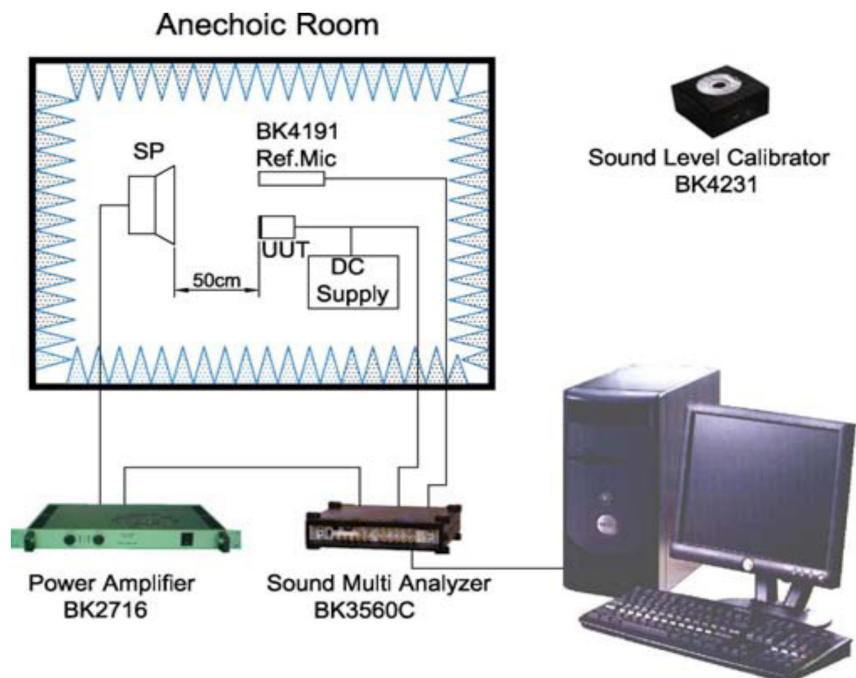

5. RELIABILITY TEST

All tests are to be carried out on the same test batch in the order listed.

The sensitivity should be within $\pm 3\text{dB}$ from initial sensitivity after 2 hours recovering on the conditioning of

20°C.

Temperature Test	After exposure at 70°C for 200 hours, the sensitivity should be within ± 3 dB from the initial value.
	After exposure at -40°C for 200 hours, the sensitivity should be within ± 3 dB from the initial value.
Humidity Test	After exposure at $60\pm 3^\circ\text{C}$ and 90~95% relative humidity for 200 hours, the sensitivity should be within ± 3 dB from the initial value.
Temperature Cycle Test	After exposure at -40°C for 60 minutes, at 20°C for 10 minutes, at 70°C for 60 minutes, at 20°C for 10 minutes, for 10 cycles, the sensitivity should be within ± 3 dB from the initial value.
Vibration Test	To ensure no effect on use after vibrations, 10 Hz to 50 Hz for 1-minute at full amplitude of 1.52 mm, for 2 hours at 3 anises test are carried out.
Drop Test	To ensure no effect on use after being dropped, the test microphone in its packaging is dropped on a concrete floor from a height of 1.5-meter on 3 faces of the packaging for 12 cycles.

6. DIMENSION(Unit : mm)

Fig.3

